

## Skandia™ Shelving

## Assembly Instructions

Please read all of the information below before you begin assembly.

To assemble your Skandia™ Shelving, you will need a tape measure, level, pencil and a #2 Phillips screwdriver.

### Basic Components

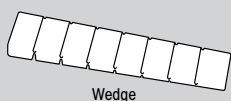
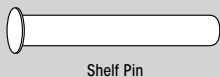
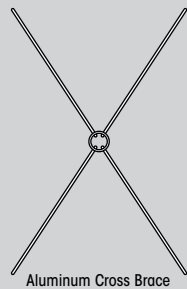
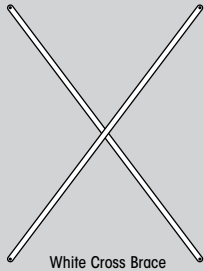
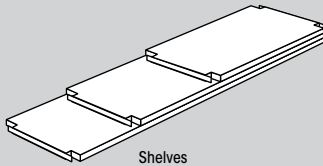
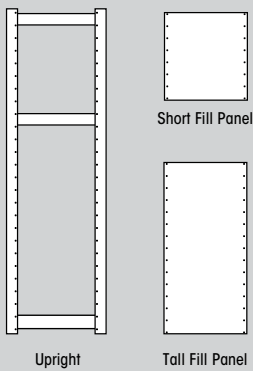

### Shelf Information

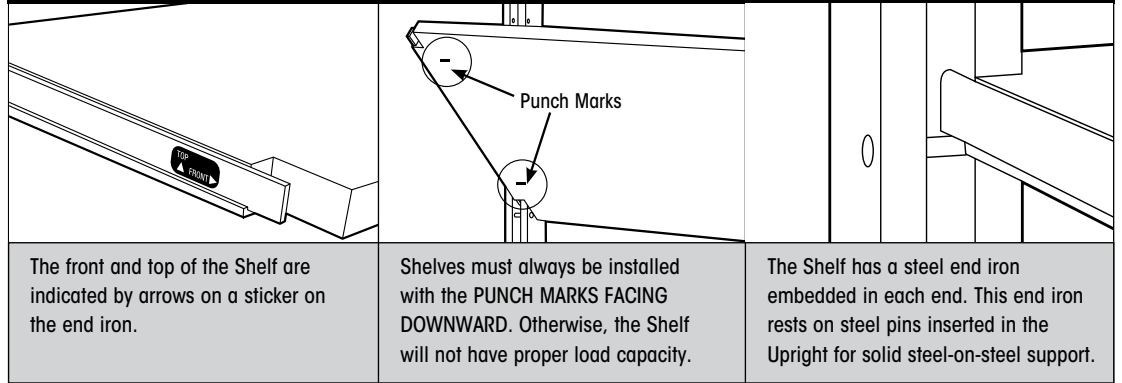

### 1 Fill Uprights and Insert Shelves

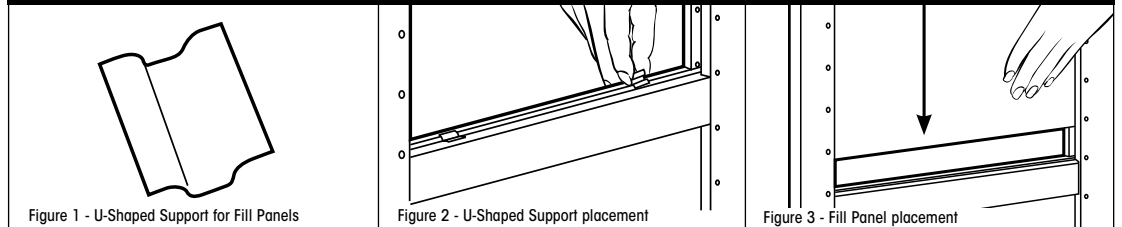

*Note: If you are not using Fill Panels, proceed to B.*

- A. If using Fill Panels, work from bottom of the Upright to the top. Insert two metal U-Shaped Supports (Figure 1) in the horizontal cross rail slot of the Upright (Figure 2). Gently guide the Fill Panel into the grooves at the top of the Upright (Figure 3).
- B. Stand a pair of Uprights side by side. Insert four Shelf Pins for each of the three Shelves into the Uprights at the top, bottom, and middle (Figure 4). Insert all three Shelves into the Uprights making sure they are resting on the Shelf Pins.

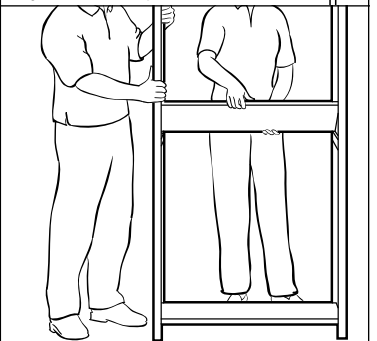

### 2 Attach White or Aluminum Cross Brace

- A. When using the White Cross Brace, just open the Cross Brace and it is ready to attach. Proceed to C on back.
- B. When using the Aluminum Cross Brace, place rods through the ring, then loosely screw the cap nuts onto the rods (Figure 1). When attaching the Cross Brace to the Upright (as described in C and D on back), make sure that all four rods are attached with the flat ends flush against the Upright (Figure 2). After you attach the Cross Brace to the Uprights, tighten the Cross Brace cap nuts (Figure 1). Do not over tighten.

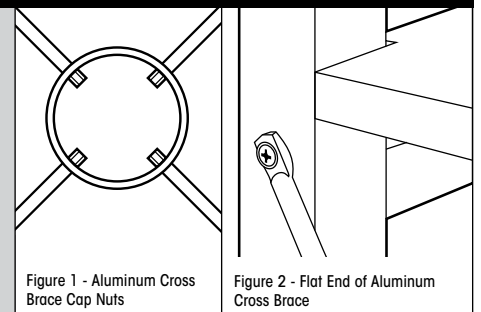

## 2 Attach White or Aluminum Cross Brace continued

C. Level and square your Skandia™ (Figure 3). Make sure the Cross Brace is at the same height from the bottom on each Upright (Figure 4). Use a pencil to mark the spots where the Cross Brace is to be fastened onto the Uprights.

D. Attach the Cross Brace with the screws provided at points A & B using a #2 Phillips screwdriver (Figure 5). Continue to level and square your Skandia™ and attach at points C & D.

**Helpful tip:** To make sure your Skandia™ is square, (the Shelf is 90° to the Upright) simply stand a Shelf vertically on the bottom Shelf and position it against the Upright to form a 90° angle.

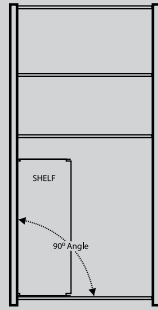

Figure 3

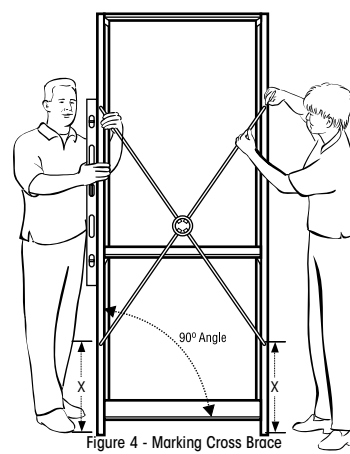

Figure 4 - Marking Cross Brace

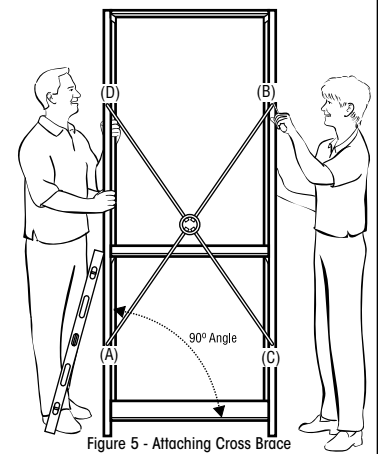

Figure 5 - Attaching Cross Brace

## 3 Level your Skandia™ Unit

*Note: Place your Skandia™ unit where you would like it in your room.*

A. While holding a level against the Upright, both front and side, gently lean the unit back or to the side and slide the Wedge underneath the Upright until it is level (Figure 1). Repeat for every Upright as necessary.

B. When your Skandia™ unit is level, simply snap off the Wedge at the closest perforation.

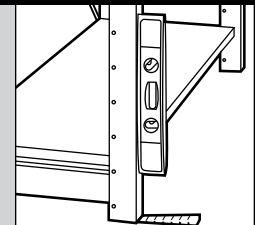

Figure 1 - Level with Wedge

## 4 Insert Remaining Shelves

A. Insert remaining Shelves using Shelf Pins. (Refer to Shelf Information on front page.)

B. If you are adding Shelves on either side of the unit, insert Shelves between one of the existing Uprights and an additional Upright. Level the additional Upright as described in Step 3 above. An additional Cross Brace is needed on every other Skandia™ unit.

## Other Components

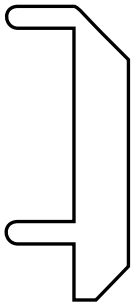

Figure 1 - Kickboard Pin

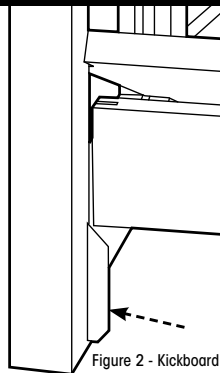

Figure 2 - Kickboard

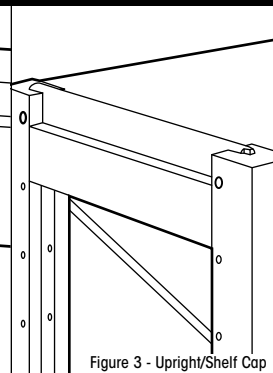

Figure 3 - Upright/Shelf Cap

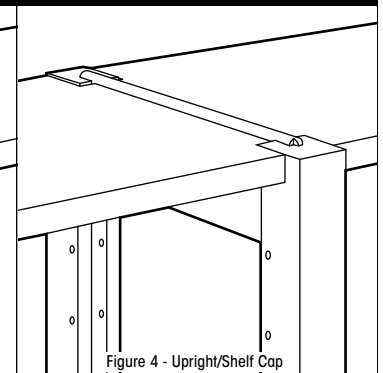

Figure 4 - Upright/Shelf Cap

### Kickboard

- Insert Kickboard Pins into bottom two holes at the front of the Upright. The long end should be pointing downward (Figure 1).
- Slide the Kickboard grooves over the Kickboard Pins (Figure 2) with the finished side facing out.

*Note: When installing a Shelf on top of the Kickboard, use Shelf Pins to support the back of the Shelf only. The Kickboard Pins serve as the Shelf Pins for the front of the Shelf.*

### Upright/Shelf Cap

An Upright/Shelf Cap may be used at the end of a Shelf (Figure 3) or between Shelves (Figure 4). Simply slide the Cap into position over the Shelf Pins.

**Care Instructions:** To care for your Skandia™, we recommend using an ostrich feather duster or a damp cloth to wipe it clean. Since Skandia™ is lacquered, you do not need to use a spray wax, furniture polish or similar product.

If you have questions about Skandia™, please call a store near you or call 1-800-733-3532  
(Monday through Saturday, 8 am to 8 pm and Sunday 9 pm to 7 pm Central Time.)