

## Quick Reference Guide

Hardware	page 1
Top Track, Hanging Standards and Top Track Cover	page 2
Solid Shelving	page 3

If at any time during installation you have questions, call the store listed on your receipt or 800-733-3532. You may also visit [containerstore.com/installation](http://containerstore.com/installation) to view video instructions.

**Tools needed:** pencil, level, power drill, drill bit set, #2 Phillips head bit for power drill, #2 Phillips head screwdriver, hammer, tape measure, ladder or step stool, Elfa 2' spacer, plastic mallet, scissors.

### TIP

- Remove all contents from your space and donate or sell all items no longer needed.
- For closets, hang clothes that you are keeping on a garment rack outside the closet during installation.
- Take out any old shelving and/or closet rods. Patch and repaint walls.
- Tape the page(s) of your custom Elfa design to the corresponding wall.
- Refer to your design for placement of your Elfa. Lay out all the products by type, size and wall.

## Hardware

Based on what you have told your designer, you have been provided with the correct hardware needed to complete the installation based on your wall construction. Below are instructions for installing each type of hardware:

### 1 Wood Screw

Used for mounting the Top Track into drywall over wood studs or directly into wood.

Drill a hole with a 1/8" drill bit the length of the drill bit.

### TIP

- Rake the wood screw over a bar of soap before inserting it into the wall. This will make tightening the screw easier.

### 2 Drywall & Plaster Anchor

Used for mounting the Top Track into 1/2" drywall (most common wall type) or 5/8" to 1" drywall/plaster.

Enlarge the hole with a 3/8" drill bit.

Remove the screw from the white anchor, ensuring the gray insert stays in place.

Tap the anchor into the hole with the plastic mallet.

Discard the grey spacers that are included in the packaging (not shown).

### 3 Sheet Metal Screw

Used for mounting the Top Track into drywall over sheet metal studs.

Drill a hole with an 1/8" drill bit the length of the sheet metal screw.

### 4 Concrete Screw

For concrete/masonry (cinder block or brick), drill a hole with a 5/32" masonry drill bit the length of the concrete screw.

For masonry with furring\*, drill a hole with a 5/32" masonry drill bit the length of the concrete screw.

\* Furring is a space usually 3/4" between the drywall and masonry surface. Furring strips are 1" x 2" pieces of wood attached to the masonry. The drywall is attached to the furring strips. When possible, the Top Track should be installed over the furring strip.



Wood Screw



Drywall & Plaster Anchor



Sheet Metal Screw



Concrete Screw

ONLY AT  The Container Store®

# elfa® Solid Shelving Installation & Assembly

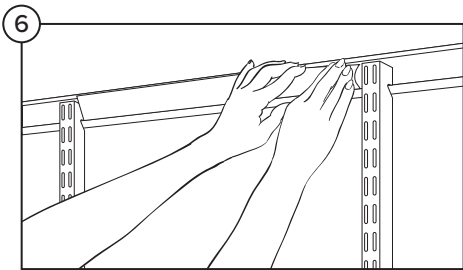
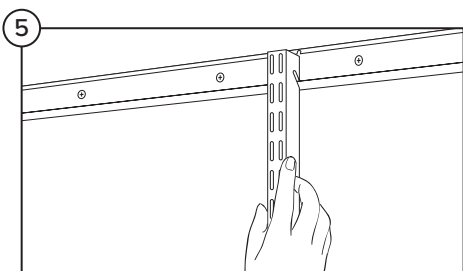
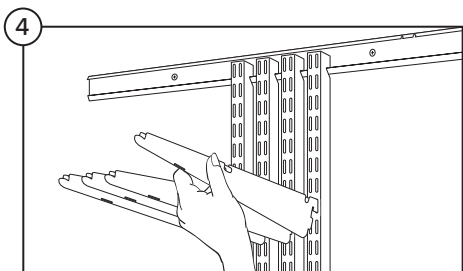
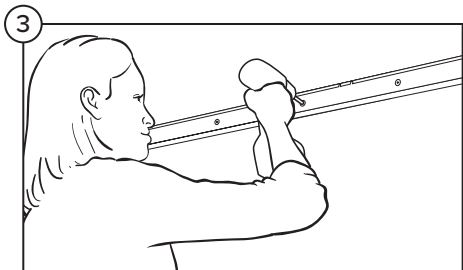
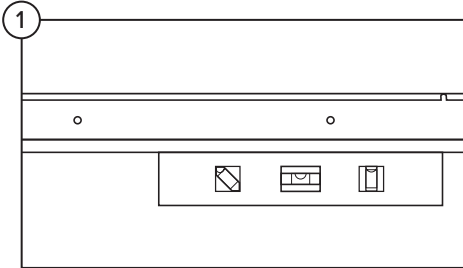

## Top Track, Hanging Standards and Top Track Cover

Tools needed: drill, screwdriver, level and pencil

### Install Top Track

- 1 Position the Track where you want to mount it, use a level to ensure it is straight. Using a pencil, mark each hole location. Be sure to keep Track level.

#### TIP

For longer Tracks, drill the center hole and secure with one screw. Tighten the screw just enough to hold the Track against the wall. Level the Track and mark the rest of the holes.

- 2 Set Track aside and drill a 1/8" hole at each location. If you hit wood, continue drilling the entire length of the drill bit. In most applications, you will not hit wood for every hole. If you don't hit a stud, mark the location. At the marked locations, enlarge that hole with the appropriate drill bit size for the hardware needed for your wall construction.
- 3 Place the Track on the wall, insert and tighten all the screws using a power drill with a #2 Phillips head bit. To avoid stripping the screws, finish hand tightening with a #2 Phillips head screwdriver.

### Install Hanging Standards and Shelf Brackets

- 4 Hang Standard on Track. Group Hanging Standards together and insert Brackets at the appropriate height for desired shelf placement.
- 5 Slide the Hanging Standards to the approximate position on the Top Track. Hanging Standards should be a minimum of 1/2" from the ends of the Top Track.

### Install Top Track Cover

#### TIP

Install your Top Track Cover ONLY after you have placed all of your components and are satisfied with positioning of your Elfa Shelving.

- 6 Start with the long pieces first. Cut Top Track Cover to size using scissors. Place top of Top Track Cover on top of the Top Track. Push the bottom part of the Top Track Cover over the bottom of the Top Track. You may need a bit of force to secure the Top Track Cover.

ONLY AT  The Container Store®

# elfa® Solid Shelving Installation & Assembly

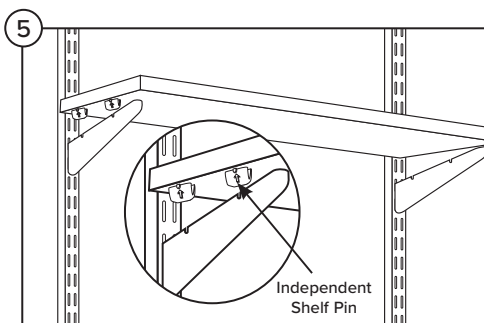
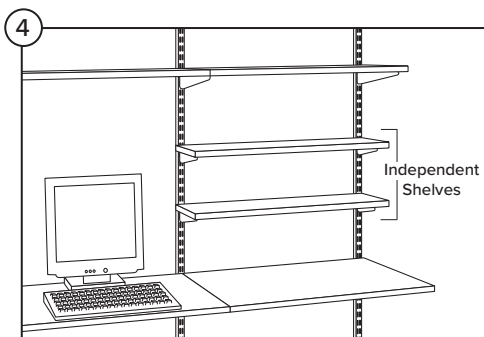
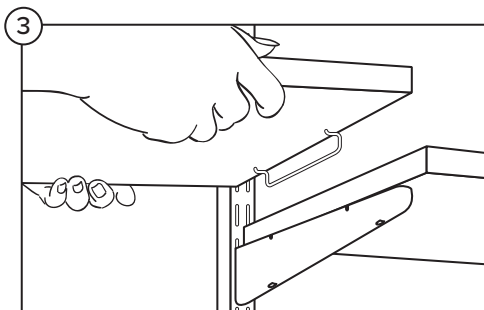
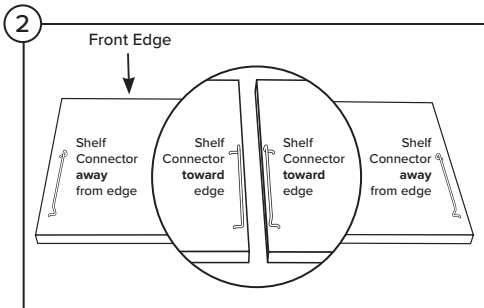
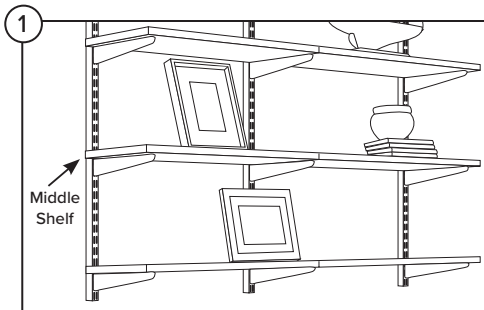

## Solid Shelving

### TIP

- There are pre-drilled holes on the bottom of the Shelf for ease of installation.
- Group Shelves by color: 30" Shelves have a blue sticker; 25" End Shelves have a green sticker; 24" Center Shelves have a red sticker. The sticker also indicates the front of the Shelf.

## Install Connected Shelves

- 1 The row of Shelving closest to the middle should be installed first.
- 2 Flip the Shelf upside down to expose the holes with the back of the Shelf toward you. Insert the Shelf Connectors as shown.
- 3 Flip the Shelf right side up and place the Shelf Connectors into the Bracket notches. Connected Shelves share a Bracket. After installing the middle row of shelving, repeat for each row of Shelves.

## Install Independent Shelves

- 4 Flip the Shelf upside down to expose the holes, with the back of the Shelf toward you.
- 5 Insert Independent Shelf Pins with the arrow to the outside edge of the Shelf. Flip the Shelf right side up and place the Independent Shelf Pins into the Bracket notches.

ONLY AT  The Container Store®

# elfa® Solid Shelving Installation & Assembly

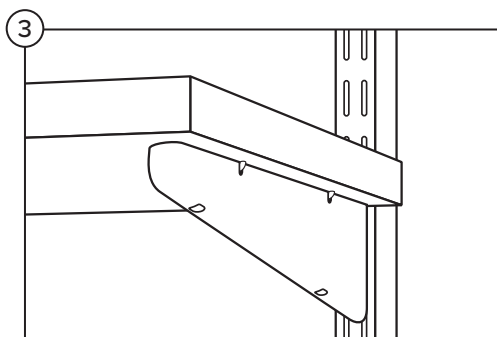
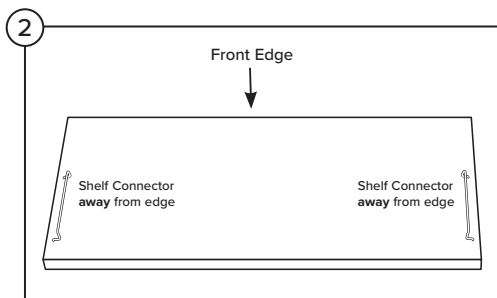
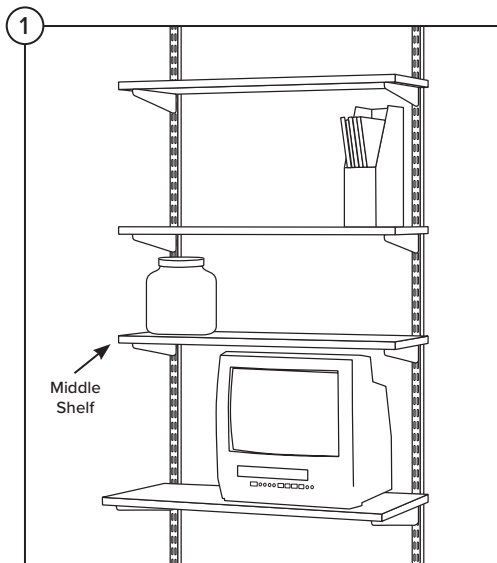

## Install Single Section of Shelving

### TIP

- There are pre-drilled holes on the bottom of the Shelf for ease of installation.

- 1 The Shelf closest to the middle should be installed first.
- 2 Flip the Shelf upside down to expose the holes with the back of the Shelf toward you. Insert the Shelf Connectors as shown.
- 3 Flip the Shelf right side up and place the Shelf Connectors into the Bracket notches. After installing the middle shelf, repeat for the other Shelves.

## Install Using Shelf Screws (not shown)

**Additional tool needed:** awl (or similar pointed tool)

### TIP

- Shelf Screws are an alternative to using Shelf Connectors. They are used with Desk Tops and on rare occasions with Solid Shelves when it is necessary for the Shelves to remain fixed.
- Place the Desk Top on the Brackets and use a pencil to trace an outline of the Brackets.
- Take the Desk Top off the Brackets and flip it upside down on a solid surface with the pencil marks visible.
- Take a Bracket out of a Hanging Standard to use as a guide. Place the Bracket over each Bracket outline on the Desk Top and use an awl to punch a mark for the screws through each hole in the Bracket. Be sure to keep the awl straight.
- Remove the Bracket and use a 1/8" drill bit to drill a hole at each punch mark.
- Place the Desk Top on the Brackets and align the holes in the Shelf with the corresponding Shelf Bracket holes.
- Insert the shorter screw in the front hole and the longer screw in the back hole of each Bracket.
- Tighten each screw with a #2 Phillips head screwdriver.

ONLY AT  The Container Store®