

A

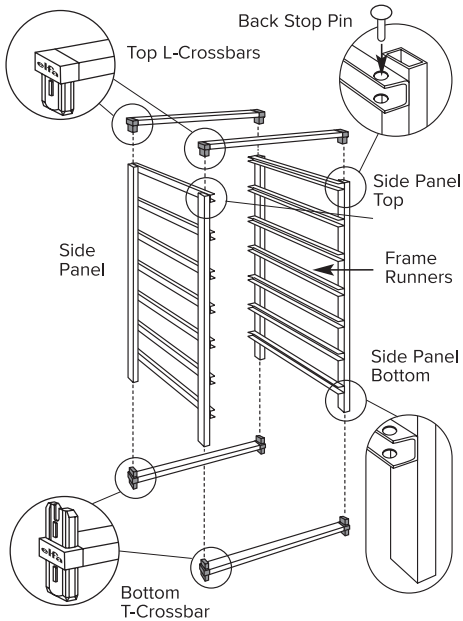

Tools needed: plastic mallet

TIP

If you don't have a plastic mallet, you can use a hammer with a wood block or towel to protect the Frame.

A Build Elfa Frames and Drawers

- Position the Elfa Frame Runners facing inward.
- Using a plastic mallet, tap the Bottom T-Crossbars into the bottom of each Side Panel. (The notched side goes into the frame.)
- Flip the unit over, and if using Back Stop Pins, put a Back Stop Pin in each of the back holes of the top Frame Runners before inserting the Top L-Crossbars. To keep Pins from "jumping" out of the hole while tapping the Top L-Crossbars in place, cover with a piece of tape.
- Using your mallet, tap the Top L-Crossbars completely into each Side Panel.
- Insert the remaining Back Stop Pins.
- Repeat for the other Drawer Solution.

B

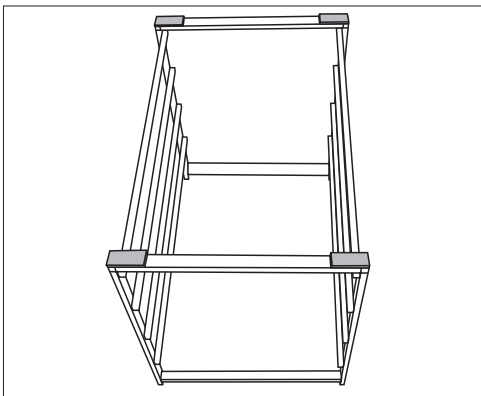
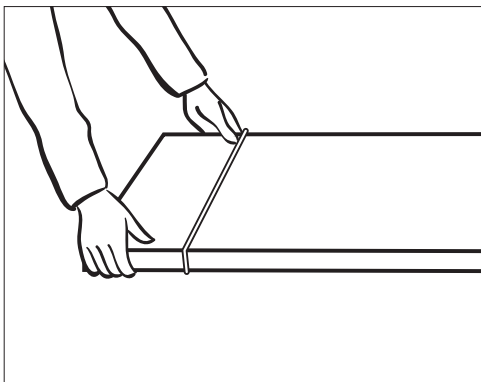

B Attach the Desk Top

- Note: If your Desk Top does NOT have rounded corners, there is no designated top or bottom surface.
- Place one Band-It® on either end of the Desk Top, about 3" from the edge, taking care to leave room for the adhesive strips in the next step.

C

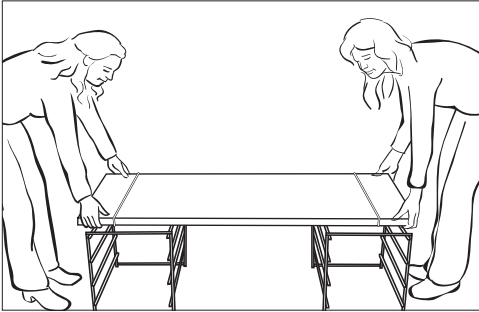
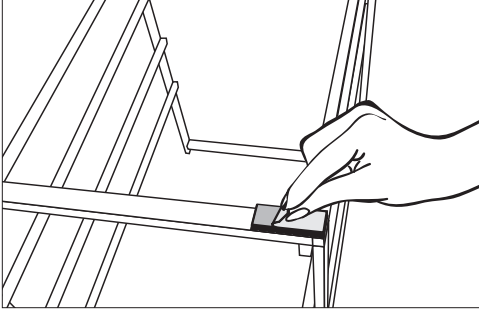

C Attach the Desk Top (continued)

- Place adhesive strips provided in the packaging on the top L-Crossbars.
- Remove the protective backing from the adhesive strips on top of the Drawer Solutions.
- When determining placement of the Desk Top, keep in mind that the Drawer Solutions should be spaced far enough apart to allow room for a child's chair.
- Carefully place the Desk Top on top of the Drawer Solutions, making sure there is about a 1" overlap of the Desk Top. Press firmly to secure.
- Slide in Drawers.

D

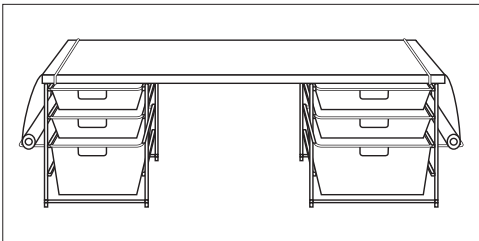
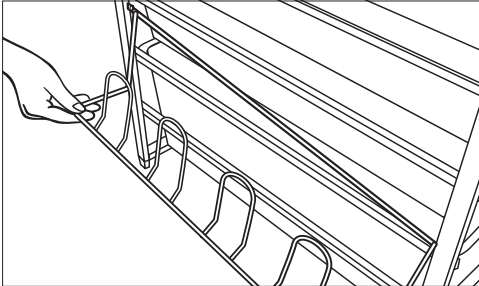

D Attach Hangmate Accessory Files

- The two Elfa Hangmate Accessory Files, which will hold the roll of drawing paper, should be attached to the outside of the completed solution. Each should be placed on the second runner up from the floor on both sides.
- Angle the Hangmate so that one end slides behind the Frame, then drop the other end into place. Repeat on the other side.
- Once both Elfa Hangmate Accessory Files are in place, the roll of paper can be placed on one end and threaded under the Band-Its® to the other side.
- Slide in the Drawers.