

elfa[®] DRAWER UNIT ASSEMBLY INSTRUCTIONS

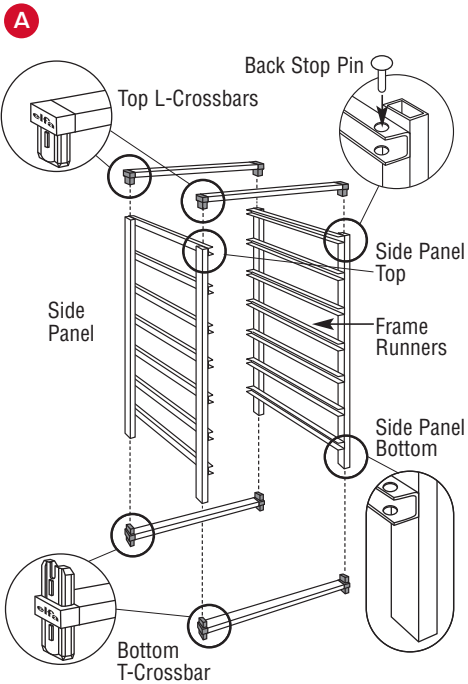

Tools needed: plastic mallet

TIPS FOR GETTING STARTED

- If you don't have a plastic mallet, you can use a hammer with a wood block or towel to protect the frame.
- Take care to protect the floor.

A Assembling a Single Frame

- Position the Side Panels with the runners facing inward.
- Using a plastic mallet, tap the Bottom T-Crossbars into the bottom of each Side Panel.
- Put a Back Stop Pin in the back holes of the top runners. To keep Pins from "jumping" out of the hole while tapping the Top L-Crossbars in place, cover with a piece of tape. The remaining Back Stop Pins should be put in place just prior to sliding in the Drawers.

IF COMBINING FRAMES, SKIP TO (B) NOW.

- Tap the Top L-Crossbars down part way, remove tape and tap completely into each Side Panel. If using a Melamine Top, place adhesive strips included in the packaging on the Top L-Crossbars. Align the Melamine Top with the crossbars and press firmly.

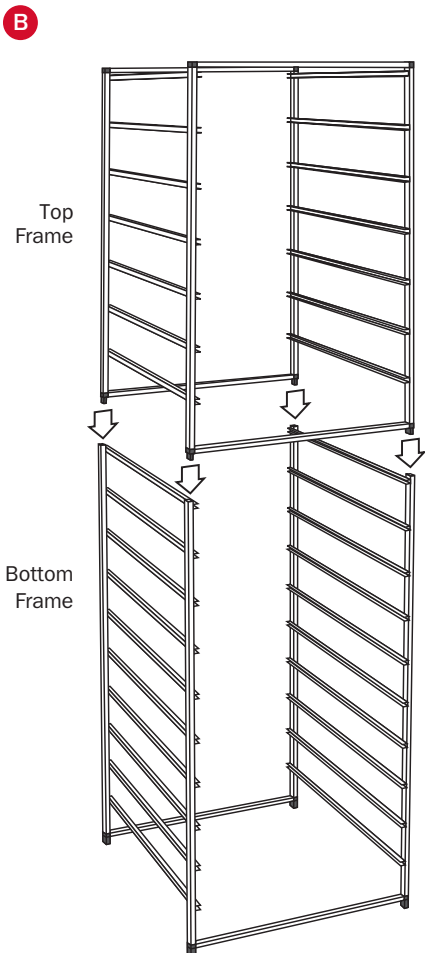

B Combining Frames

- Assemble the top frame completely. (See instructions above.)
- Assemble the bottom frame, omitting the Top L-Crossbars.
- If using Back Stop Pins, put one in the back of the left and right top runners of the bottom frame.
- Lower the top frame onto the bottom frame, making sure the Back Stop Pins are all on the back side. Secure by firmly tapping each corner of the top frame until Bottom T-Crossbars are completely inserted into the bottom frame.

Inserting Drawers

- Insert the remaining Back Stop Pins.
- Slide in the Drawers.
- If you have other Elfa Frame and Drawer accessories, add them now.