

ASSEMBLY INSTRUCTIONS

Classic Lines 3-Tier Tower

16 in × 13 in × 33 in
(40.6 cm × 33.0 cm × 83.8 cm)





Patents Pending

CAUTION

- 1) Do NOT over tighten the screws. Doing so may damage the unit.
- 2) Do NOT place the unit in high temperature area or near appliances that emit large amount of heat.
- 3) Do NOT place the unit in direct sunlight as it may cause the color to fade.
- 4) Do NOT place the unit on uneven surfaces. Doing so may cause the unit to tip over.
- 5) Examine the screws periodically and tighten them if they are loose.
- 6) Weight capacity: 75 lb per shelf
- 7) Check unit to ensure that it is level before use.

PARTS LIST

Please check the parts you received according to the parts list below.

	 (A) (B)
Folded 3-Tier Tower (1 pc)	(A) Long Screw (6 pcs) pre-inserted in the unit (B) Short Screw (6 pcs)

*Tool needed: Phillips Screwdriver and Level

Please Note:

- 1) Do NOT place the unit vertically when unfolding as this may result in the unit suddenly unfolding and pinching your fingers.
- 2) Find a flat surface or floor to assemble the unit. Using an uneven surface or floor to assemble the unit may result in uneven/unlevel shelves, which can compromise strength of the unit.
- 3) Check unit before using to ensure it is level.
- 3) If the unit is uneven/unlevel after assembled, loosen both screws (A & B), adjust the unit and then retighten the screw (A & B).

ASSEMBLY INSTRUCTIONS

Step 1: Use a Phillips screwdriver to loosen the 6 Long Screws (A) that have already been pre-inserted in the unit. Do NOT remove the screws from the unit. Simply loosen them to allow the unit to unfold. Next, place the compressed unit horizontally and position your hands to carefully unfold the unit.

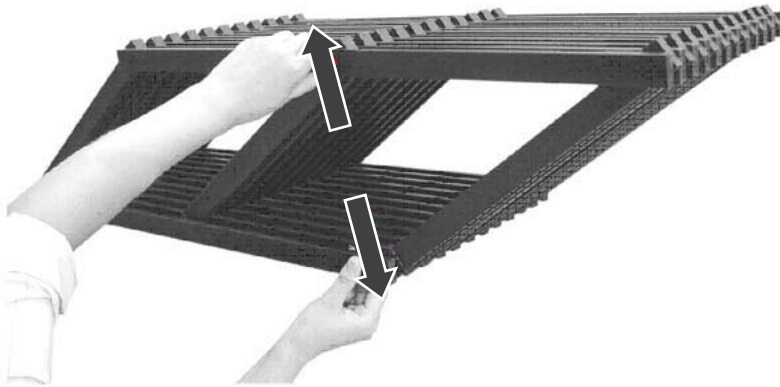

3

Step 2: Refer to the picture below. First, tighten the 6 pre-inserted Long Screws (marked "A" in the picture). Next, screw in and tighten the 6 Short Screws (B) into the 6 screw holes on the unit (these screw holes are marked "B" in the picture). Do NOT over tighten the screws.

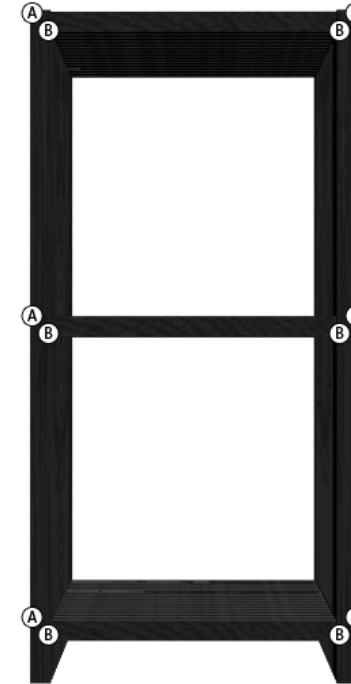

How to Fold the Tower (If Needed): First, fully loosen and remove all 6 Short Screws (marked "B" in the picture above) from the unit. Next, fully loosen (about 5 turns), but do NOT remove, the 6 remaining pre-inserted Long Screws (marked "A" in the picture above). Finally, carefully fold down the unit. Please note that the unit CANNOT be folded completely flat. Forcing the unit into a folded position without first removing the 6 Short Screws (B) and fully loosening the 6 pre-inserted Long Screws (A) may result in irreparable damage to the unit.

4