

The Container Store[®]

Assembly Instructions Copenhagen Stacker

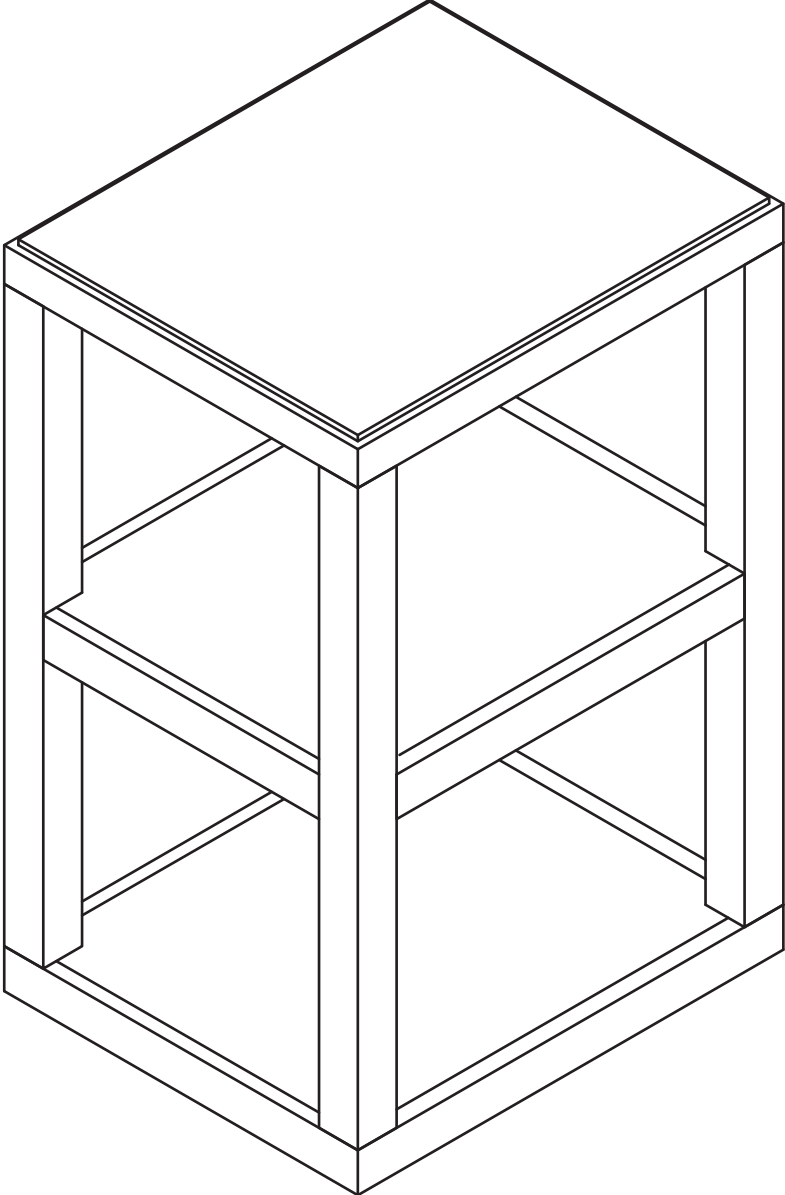

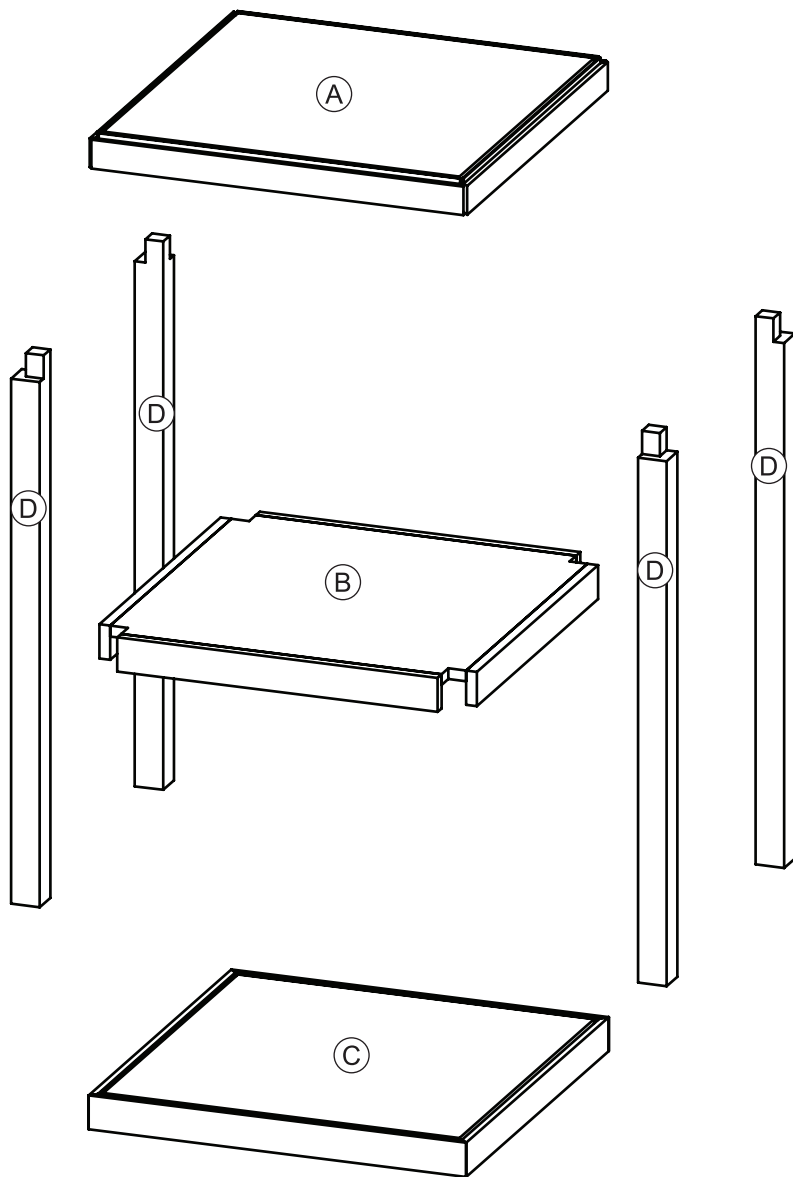

A	Top Shelf	1
B	Middle Shelf	1
C	Bottom Shelf	1
D	Leg	4

Please review the hardware listed on the next page as well as individual components of this product. As you unpack and prepare for assembly, place the contents on a carpeted or padded area to protect them from damage.

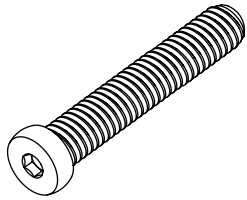

**H1 x 12
BOLT**

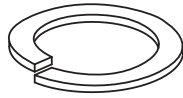

**H2 x 12
LOCK
WASHER**

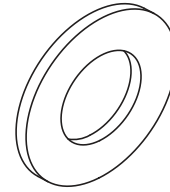

**H3 x 12
WASHER**

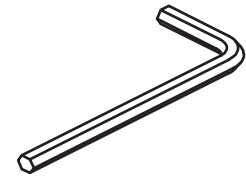

**H4 x 1
ALLEN
WRENCH**

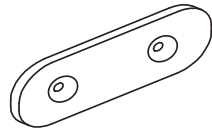

**H5 x 2
MENDING
PLATE**

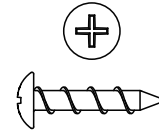

**H6 x 4
5/8"
SCREW**

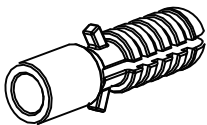

**H7 x 1
WALL
ANCHOR**

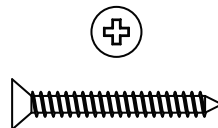

**H8 x 1
WALL SCREW**



**H9 x 1
WALL STRAP**

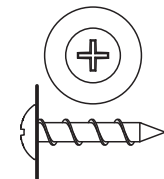

**H10 x 1
TRUSS-HEAD
SCREW**

TOOLS REQUIRED: HAMMER & DRILL (FOR ANTI-TIP ATTACHMENT)

STEP 1

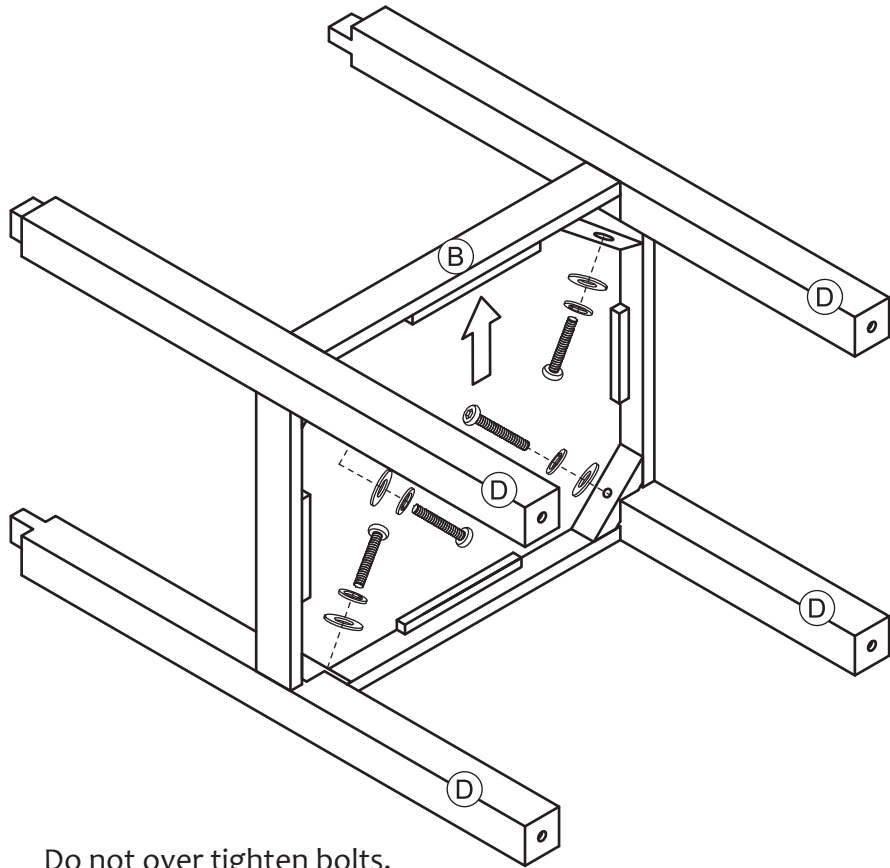

Do not over tighten bolts.

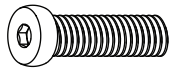

H1 x 4
BOLT

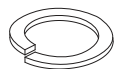

H2 x 4
LOCK
WASHER

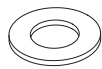

H3 x 4
WASHER

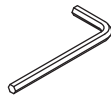

H4 x 1
ALLEN
WRENCH

STEP 2

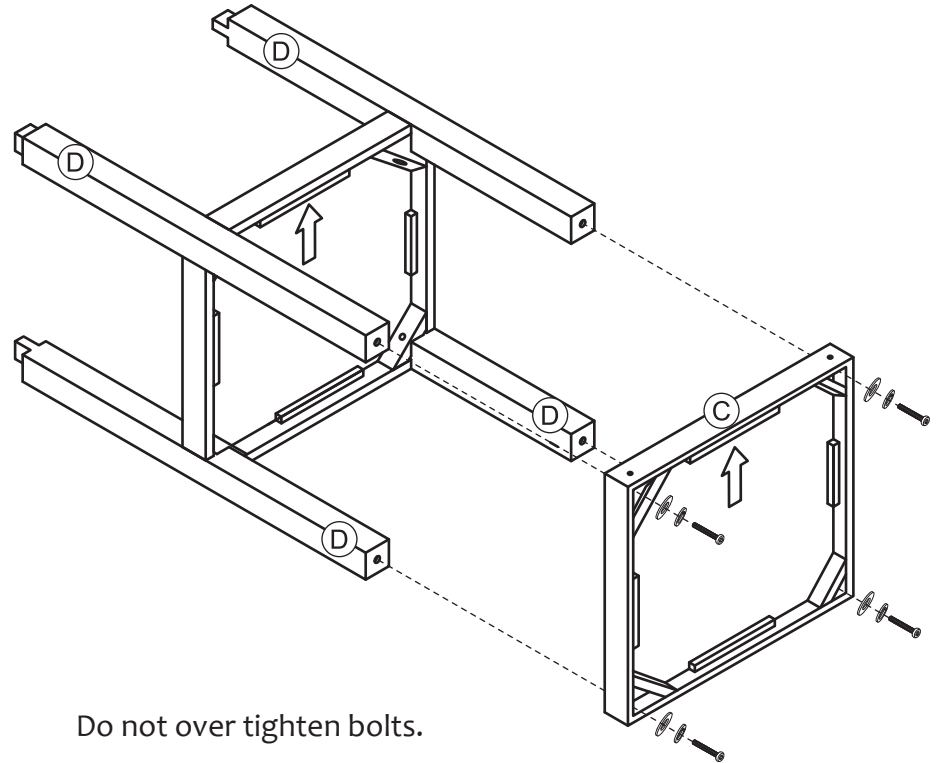

Do not over tighten bolts.

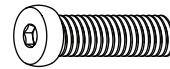

H1 x 4
BOLT

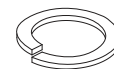

H2 x 4
LOCK
WASHER

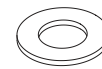

H3 x 4
WASHER

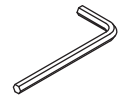

H4 x 1
ALLEN
WRENCH

STEP 3

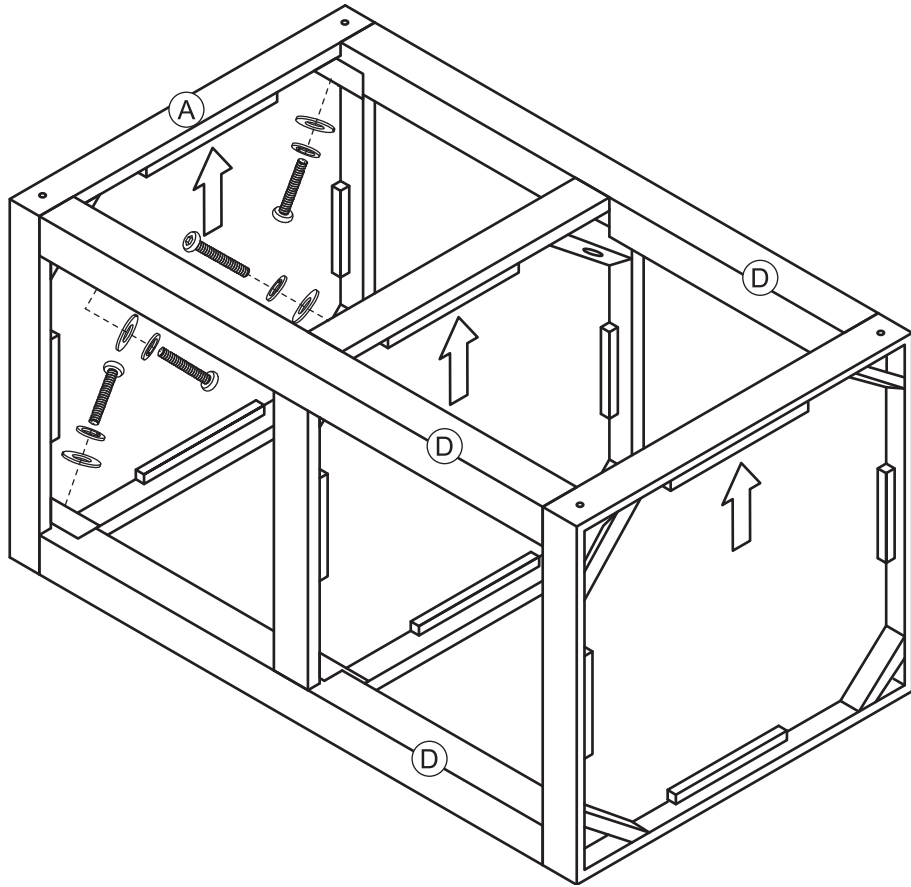

Do not over tighten bolts.

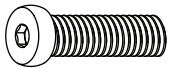

H1 x 4
BOLT



H2 x 4
LOCK
WASHER

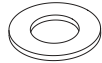

H3 x 4
WASHER

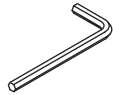

H4 x 1
ALLEN
WRENCH

STEP 4

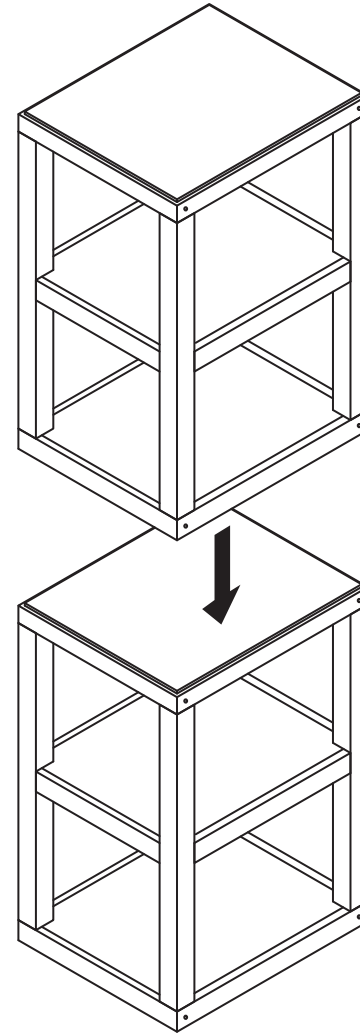

**STACK MODULAR UNITS ON
ONE ANOTHER TO CREATE
ADDITIONAL SHELVING.**

STEP 5

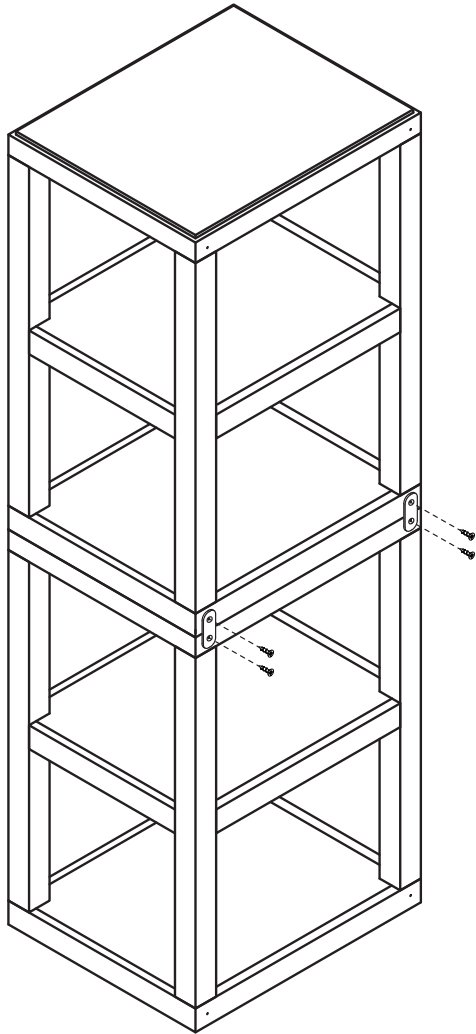

ATTACH MENDING PLATE
BETWEEN TWO STACKERS
IN LINE WITH LEGS. USE
PROVIDED 5/8"
SCREWS TO ATTACH.

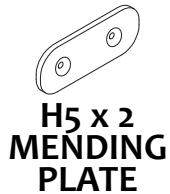

ANTI-TIP KIT

1. ATTACH WALL STRAP TO TOP EDGE OF STACKER WITH TRUSS-HEAD SCREW.
2. PLACE STACKER IN DESIRED LOCATION, MARKING POSITION OF WALL STRAP ON WALL.
3. DRILL 17/64" HOLE AT MARKED POINT.
4. TAP WALL ANCHOR INTO DRILLED HOLE.
5. USING WALL SCREW, SECURE WALL STRAP INTO WALL ANCHOR.
6. ENJOY FURNITURE.

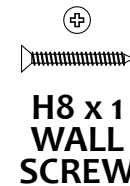
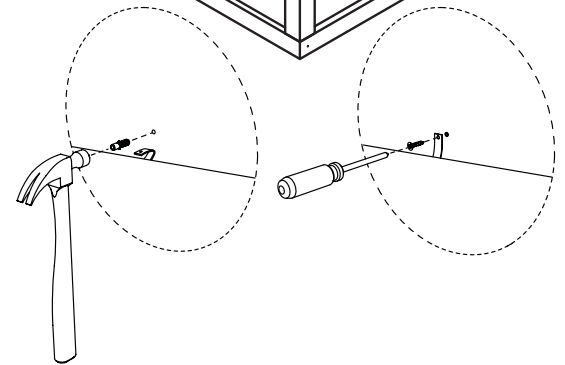
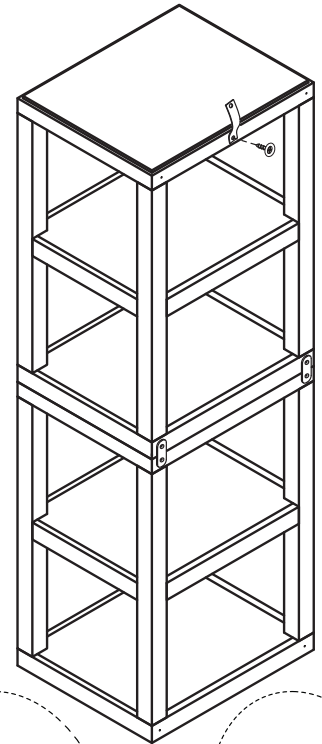

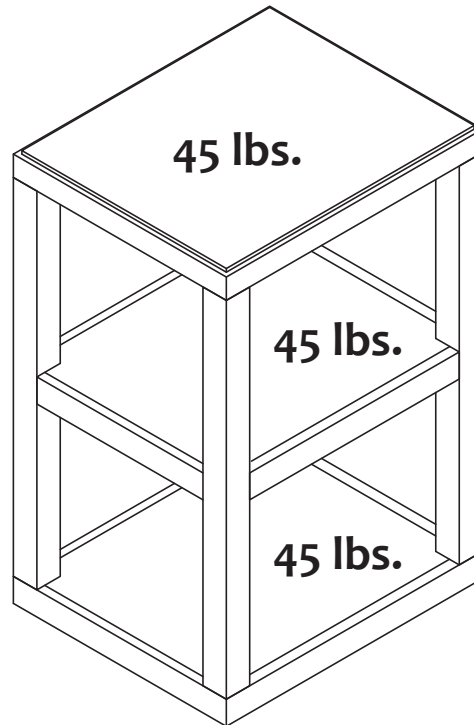

WARNING: Do not exceed the recommended weight limits on the designated panels. Exceeding these limits could cause sagging, possibly resulting in failure of product or bodily injury. Severe injury may occur if furniture tips over. Never allow children to climb or play on this product. Place heaviest items on lower shelves and as far back as possible, never overload product.